

# PHILCO . . . . . Model 37-61



**Special Data for Members of  
RADIO MANUFACTURERS SERVICE**  
A PHILCO SERVICE PLAN

**SERVICE BULLETIN  
No. 246**

## Model 37-61

### General Description

Model 37-61 is a 5 tube superheterodyne receiver for operation on alternating current and has two tuning ranges, covering standard broadcast and short wave reception. It, also, uses the new Philco High Efficiency self-centering glass tubes.

The circuit includes the Philco Foreign Tuning System—controlled by the range switch—providing maximum sensitivity and noise reduction when used with the New Philco High-Efficiency Aerial, supplied with the receiver.

The red and black leads of the High-Efficiency Aerial "transmission line" are connected to terminals 1 and 2 respectively, of the terminal panel provided at the rear of the chassis. Connect the jumper of the terminal panel across terminal 3 and 4. A good ground connection is required in all installations. Make the ground connection to terminal 3 on the terminal panel.

If a temporary aerial is used, the jumper should be across terminal 2 and 3. The aerial connects to terminal 1 and the ground to terminal 3.

### CONSTRUCTION

The chassis is constructed in three basic assembly units.

The Radio Frequency unit contains a 6A8G tube which functions as a Detector-Oscillator, tuning condenser, antenna and oscillator coils for each tuning range, selector switch—compensating condensers for all coils and other parts necessary for the associated circuits. The unit is separately mounted on rubber grommets, cushioning it from the main chassis.

The Intermediate Frequency unit, mounted on the right-hand side of the chassis facing the front, consists of the Intermediate

Frequency coils, compensating condensers, a 6K7G tube for I. F. Amplifier stage, and a 6Q7G tube as the second detector-automatic volume control and first audio stage. All voltages supplied to the I. F. and R. F. units are furnished from a terminal strip mounted in this unit.

The Power Pack and audio output circuits, together with the required Voltage dividers and filter condensers are mounted in the power unit. All high Voltage A. C. Wiring is housed in the power transformer assembly which includes the rectifier socket.

Although unit construction has changed the appearance of this model, the service bulletin will be of great assistance in checking through all stages of the receiver. The Wiring Diagram, as usual, is numbered, indicating all important parts. These numbers correspond with the parts layout shown in Fig. 6. In addition, the range switch wafers are shown on the schematic diagram. The contacts on each wafer are lettered and numbered to indicate their connection points in the schematic diagram, which are also lettered and numbered. The physical drawings of each coil used in the receiver are also shown on schematic diagram Fig. 5. The connections of these coils are numbered on the coil itself and on the schematic diagram.

Fig. 1 shows the Voltage measurements taken from the bottom of the socket at each contact. In Fig. 2, the correct position of the dial indicator, for proper adjustment of the compensators is shown. Figs. 3 and 4 show the location of the I. F. and R. F. compensators respectively.

This receiver will be supplied in two model cabinets type B, and F. These instructions, however, will cover both type cabinets.

### Electrical Description

**Voltage Rating:** 115 Volts. A. C.

**Frequency Rating:** 50-60 Cycle.

For 25 to 40 cycle operation use Power Transformer, marked with asterisks in Parts List.

**Power Consumption:** 60 Watts.

**Type and Number of Philco Tubes:** 1 type 6A8G First Detector-oscillator; 1 type 6K7G I. F. Amplifier; 1 type 6Q7G

2nd Detector, A. V. C., and 1st Audio; 1 type 6F6G Pentode Output and 1 type 5Y4G, Rectifier.

**Speaker:** S7.

**Type of Circuit:** Superheterodyne with Pentode Power Output.

**Intermediate Frequency:** 470 K. C.

**Undistorted Power Output:** 3 Watts.

**Tuning Ranges:** Two—(1): 530 to 1720 K. C.; (2): 5.7 to 18.2 M. C.

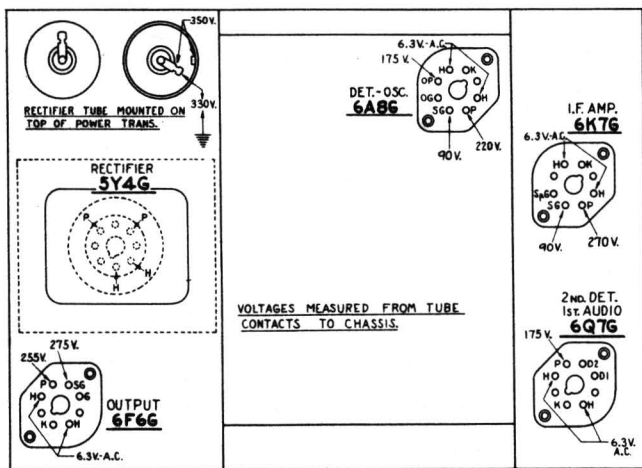

**Fig. 1—Socket Voltages  
Viewed from Underside of Chassis**

Measurements taken with PHILCO MODEL 025 Circuit Tester which contains a 1000 ohms per volt Voltmeter. Line voltage, 115—Range Switch in Broadcast Position. Dial tuned to 600 K. C.

### POWER TRANSFORMER DATA

Lead No. Shown on Schematic	A. C. Volts	Current	Circuit	Color	Resistance
1-2	120	—	Pri.	White	5 ohms
3-4	5.0	2.0A	Fil. Rect.	Blue	.1 ohm
5-7	670	70 M. A.	High Voltage Sec.	Yellow	145 ohm 155 ohm
6	—	—	Center Tap of 5-7	Yellow Green Tr.	—
8-9	6.7	2.1A	Fil.	Black	.1 ohm

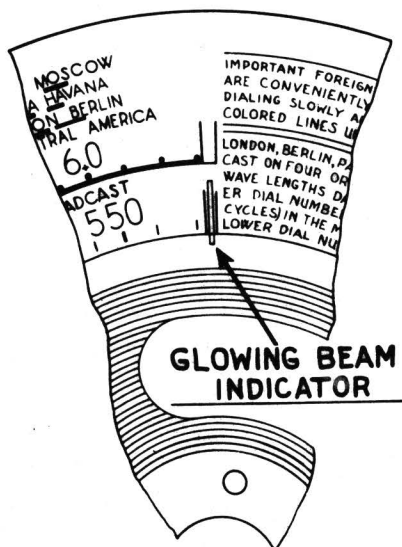

Fig. 2—Dial Calibration

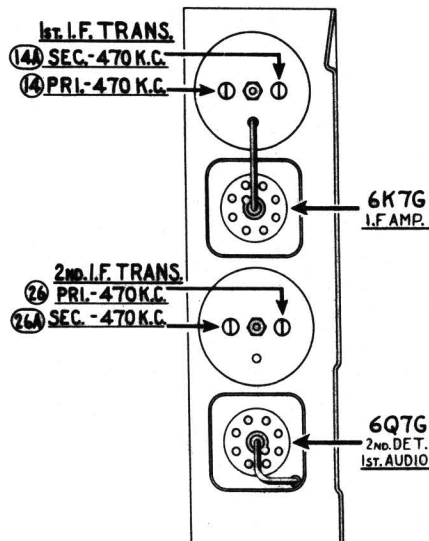

Fig. 3—Locations of I. F. Compensators Top of Chassis

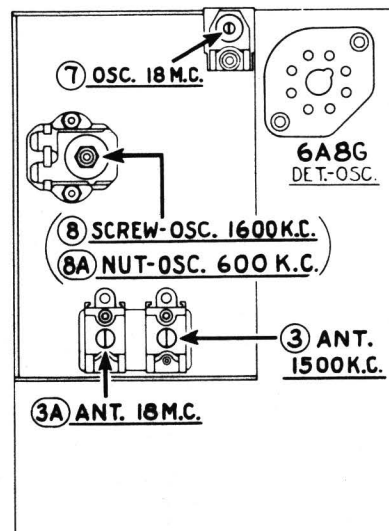

Fig. 4—Locations of R. F. Compensators Underside of Chassis

### Adjustment of Compensators

The accurate adjustment of the various compensating condensers is vital to the proper functioning of this receiver. There are four compensating condensers in the I. F. Circuit; three in the Oscillator Circuit; and two in the Antenna Circuit. Incorrect adjustment will cause loss of sensitivity, unsatisfactory tone, and poor selectivity.

To accurately adjust this receiver, precision test equipment is necessary. A signal generator such as the PHILCO MODEL 088 SIGNAL GENERATOR, covering from 110 to 20000 K. C. is recommended to adjust the compensators at the various frequencies specified. A visual indication of the receiver output is also necessary to obtain correct adjustment of the compensators. PHILCO MODEL 025 CIRCUIT TESTER contains a very sensitive output meter and is recommended for these adjustments.

Philco Fibre Wrench No. 3164 and Fibre Handle Screw-driver No. 27-7059 complete the necessary equipment for these adjustments. The locations of the various compensators are shown in Figs. 3 and 4.

The following procedure must be observed in adjusting the compensators:—

**DIAL ADJUSTMENT**—The Tuning Condenser is set at the maximum capacity position, by turning the tuning knob counter-clockwise. Loosen the set screw of dial hub and set dial, (see Fig. 2) with Glowing Indicator centered between the index lines at the low frequency end of scale.

**OUTPUT METER**—The Output Meter is connected to the Plate and Cathode terminals of the (6F6G) tube and adjusted to use the (0-30) Volt scale. When adjusting each circuit, care should be taken to have the Signal Generator attenuator set to give approximately  $\frac{1}{4}$  scale reading on output meter.

#### INTERMEDIATE FREQUENCY CIRCUIT

- 1 Turn range switch to Range 1. Rotate the tuning control to approximately 600 K. C. Connect the 088 Signal Generator output lead through a .1 mfd. condenser to the grid of the 6A8G tube.
- 2 Set Signal Generator indicator for 470 K. C. adjust attenuator for approximately  $\frac{1}{4}$  scale reading on output meter. Then adjust compensators (26a) 2nd I. F. Sec., (26) 2nd I. F. Pri., (14a) 1st I. F. Sec., (14) 1st I. F. Pri., for maximum reading on output meter.

#### RADIO FREQUENCY CIRCUIT

##### Range 2.—5.7 to 18 M. C.

- 1 Remove the signal generator output lead and series condenser from the 6A8G tube and connect them to the ANT. TERMINAL No. 1, on aerial input panel (rear of chassis) and the

generator ground lead to GND. TERMINAL No. 3, rear of chassis. Connect TERMINAL No. 2 to GROUND TERMINAL No. 3 with connector link provided on the panel.

- 2 Set range switch in position No. 2 (S. W.). Turn signal generator and receiver dials to 18 M. C. and adjust compensator (7) Osc. for maximum output.
- 3 The adjustment of the antenna compensator on the high frequency range causes a slight detuning of the oscillator circuit. In order to overcome this detuning effect, connect a variable condenser of approximately 350 mfd., having a good vernier drive, across the oscillator section of the tuning condenser. Leaving the signal generator and receiver dials at 18 M. C., tune the added condenser so that the second harmonic of the receiver oscillator will beat against the signal from the signal generator. The antenna compensator (3a) should then be adjusted to give maximum output.
- 4 Now remove the external condenser from the tuning condenser of receiver and turn compensator (7) osc. to the maximum capacity position (clockwise), then without moving signal generator or receiver tuning condenser, turn compensator (7) (counter-clockwise) until a second peak is reached on the output meter. The first peak is caused by tuning to the image frequency signal and must be neglected. Compensator (7) is adjusted on the second peak to give maximum output.

##### RANGE 1: 530 to 1720 K. C.

Turn range switch to Range No. 1. Turn the Receiver dial to 1600 K. C. Then adjust compensators (8) and (3) for maximum reading on output meter.

The 088 Signal Generator dial is set at 800 K. C. and the second harmonic of this frequency (1600 K. C.) is used in making the above adjustment.

- 2 The low frequency end of the band is now tuned by turning Signal Generator and Receiver dials to 600 K. C. and adjusting compensator (8a)—see note (a) below—for maximum output.
  - (a) When compensator (8a) osc. series is being adjusted, the Tuning Condenser must be rolled for maximum output. This is accomplished as follows: First tune compensator (8a) for maximum output. Then vary the Tuning Condenser for maximum output at 600 K. C. Now retune Compensator (8a) and again vary the tuning condenser back and forth at 600 K. C., for maximum output. This operation of first tuning the Compensator, then the Tuning Condenser is continued until maximum output is obtained at the 600 K. C. frequency.
- 3 Set the Signal Generator and Receiver Dials for 1600 K. C. and re-adjust Compensator (8) for maximum output. Then turn the dials to 1500 K. C. and re-adjust compensator (3) for maximum reading on output meter.

# PHILCO Service Bulletin

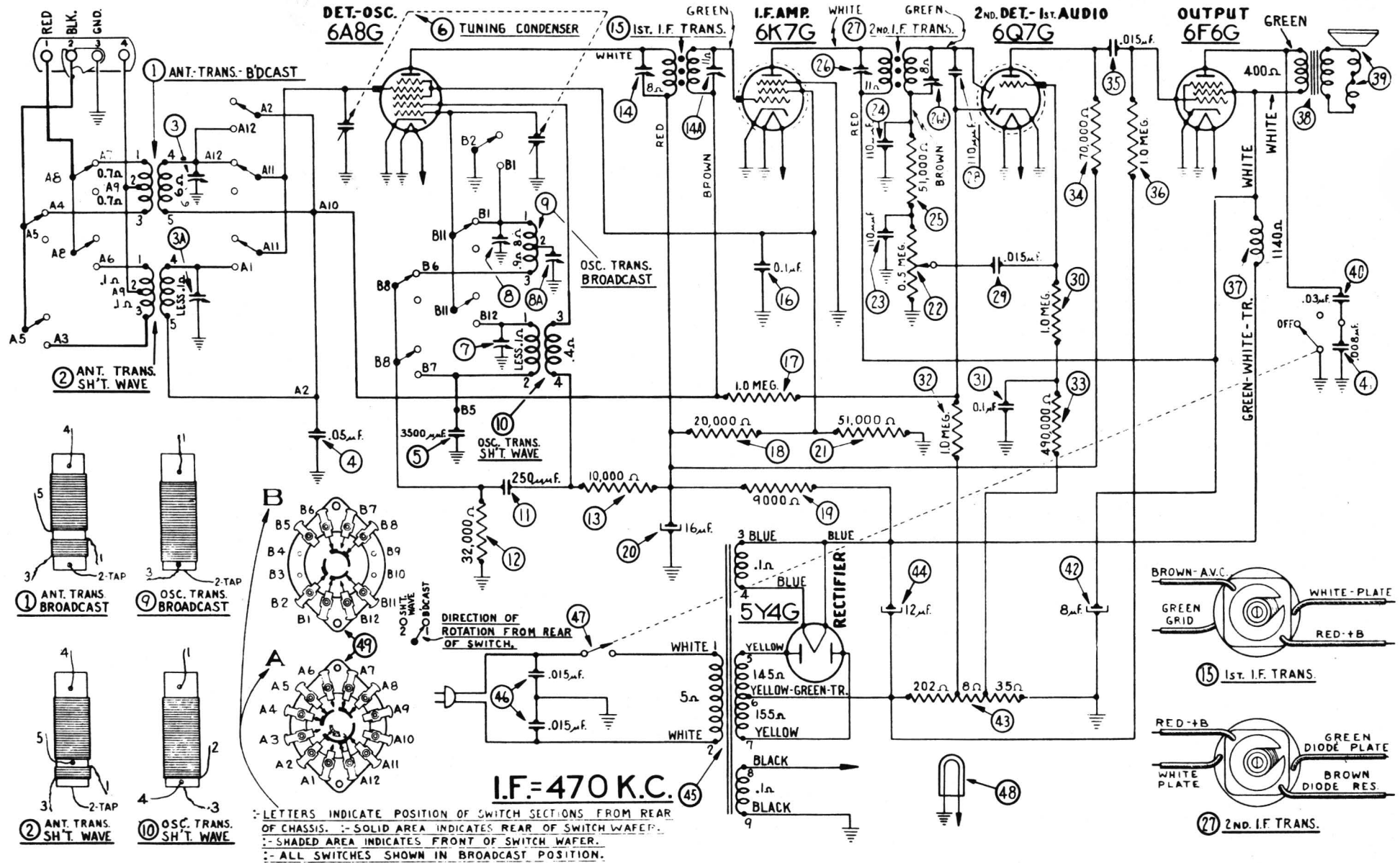

Fig. 5—Schematic Diagram—Model 37-61

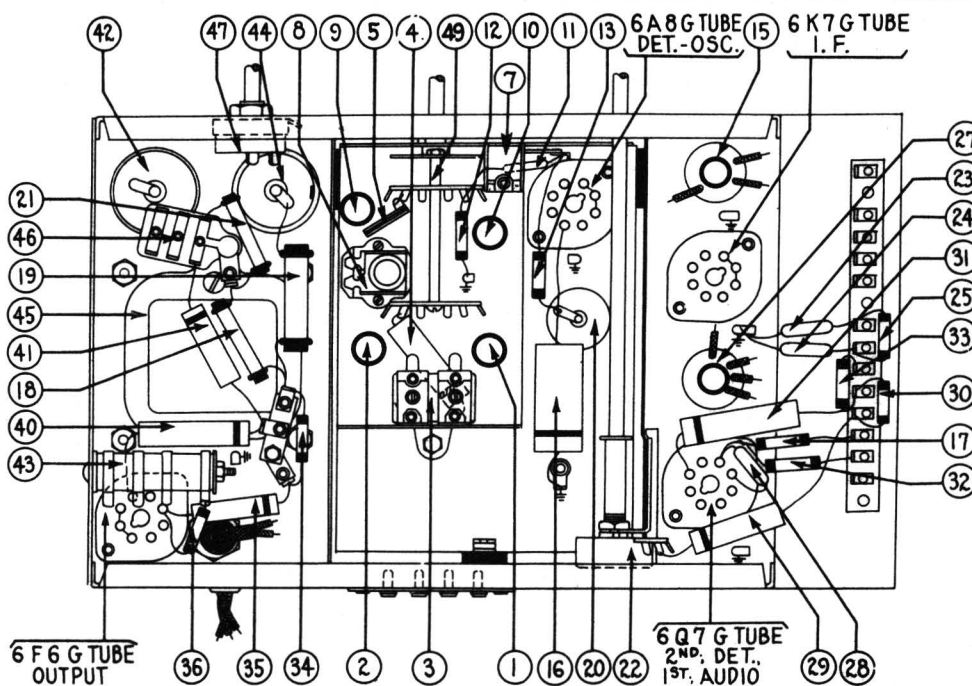

Fig. 6—Base View of Chassis

Replacement Parts—Model 37-61

Schem. No.	Description	Part No.	Price List	Schem. No.	Description	Part No.	Price List
①	Antenna Trans. Broadcast	32-2108	\$0.80	④⑨	Wave Switch Assembly	42-1195	\$1.50
②	Antenna Trans. S.W.	32-2142	.50	Dial	27-5205		
③	Compensator Twin Ant. 1500 K.C.	31-6093	.40	Dial Hub	28-7152 FA-3	.10	
④A	Compensator Ant. 18 M.C.	Part of ①		Dial Hub Clamp	28-2837 FA-3	.10	
⑤	Condenser (Tubular .05 mfd.)	30-4444	.20	Set Screw	N-1506	Per C 2.00	
⑥	Condenser Semi-fixed 3500 mfd.	31-6103	.60	Screen Bracket & Screen Assembly	31-1878	.25	
⑦	Tuning Condenser	31-1851	3.25	Pilot Lamp Socket Assembly	28-7706	.35	
⑧	Compensator Osc., 18 M.C.	31-6101	.20	Tube Socket (7-prong)	37-6067	.11	
⑨	Compensator Osc., 1600 K.C. "Screw"	31-6100	.40	Tube Socket (8-prong)	37-6058	.11	
⑩A	Compensator Osc., 600 K.C. "Nut"	Part of ①		Tube Shield	28-2726	.10	
⑪	Transformer Osc. Broadcast	32-2120	.65	Tube Shield Base	28-3898	.03	
⑫	Transformer Osc. S.W.	32-2143	.60	I.F. Coil Shield	38-7763	.20	
⑬	Condenser (Tubular 250 mfd.)	30-1032	.25	R.F. Transformer Mtg. Plate	28-3808	.02	
⑭	Resistor (32000 ohms 1/2 watt)	33-32339	.20	R.F. Transformer Mtg. Spacer	27-8228	.01	
⑮	Resistor (10000 ohms 1/2 watt)	33-310339	.20	R.F. Transformer Mtg. Screw	W-1635	Per C .30	
⑯	Compensator (1st I.F. Pri. 470 K.C.)	Part of ④		R.F. Unit Mtg. Grommet	27-4317	.04	
⑰A	Compensator (1st I.F. Sec. 470 K.C.)	Part of ④		R.F. Unit Mtg. Sleeve	28-2257 FA-3	.01	
⑱	1st I.F. Transformer	32-2100	1.50	R.F. Unit Mtg. Washer	W-425A		
⑲	Condenser (Tubular 0.1 mfd.)	30-4170	.25	Screw	W-729 FA-3	Per C .25	
⑳	Resistor (1 megohm 1/2 watt)	33-510339	.20	Tuning Condenser Mtg. Grommet	27-4325	.02	
㉑	Resistor (20000 ohm, 1 watt)	33-320439	.20	Tuning Condenser Mtg. Screw	W-650 FA-3	Per C .40	
㉒	Resistor (9000 ohms, 2 watt)	33-290539	.30	B.C. Resistor Mtg. Screw	W-512	Per C .90	
㉓	Electrolytic condenser, 16 mfd.	30-2118	1.65	B.C. Resistor Mtg. Nut	W-317A	Per C .40	
㉔	Resistor (51000 ohms 1 watt)	33-351439	.20	Volume Control Shaft	28-6498	.10	
㉕	Volume Control	33-5157	1.00	Volume Control Shaft Washer	28-4186		
㉖	Condenser (110 mmfd. Mica)	30-1031	.20	Volume Control Shaft Washer	4436	Per C 1.50	
㉗	Condenser (110 mmfd. Mica)	30-1031	.20	Volume Control Shaft Spring	28-4117	Per C .40	
㉘	Resistor (51000 ohms 1/2 watt)	33-351339	.20	Volume Control Shaft Retaining Clip	28-8610	.03	
㉙	Compensator (2nd I.F. Pri.) 470 K.C.	Part of ④		Volume Control Mtg. Nut	W-684 FA-3	Per C 1.25	
㉚A	Compensator (2nd I.F. Sec.) 470 K.C.	Part of ④		Tone Control Mtg. Nut	W-684 FA-3	Per C 1.25	
㉛	2nd I.F. Transformer	32-2102	1.50	Tone Control Insulator	27-8320	Per C .40	
㉜	Condenser (110 mmfd. Mica)	30-1031	.20	I.F. Terminal Panel	38-7703	.25	
㉝	Condenser (.015 mfd. Tubular)	30-4358	.20	Vernier Tuning Assembly	31-1879		
㉞	Resistor (1 megohm 1/2 watt)	33-510339	.20	Vernier Tuning Screws	W-1599 FA-3	Per C .25	
㉟	Condenser (0.1 mfd. Tubular)	30-4122	.20	I.F. Terminal Spacer	28-4001	.10	
㊱	Resistor (1.0 megohm 1/2 watt)	33-510339	.20	Knob Tuning	27-4330	.10	
㊲	Resistor (490,000 ohm 1/2 watt)	33-449339	.20	Knob Tuning Vernier	27-4331	.10	
㊳	Resistor (70000 ohm 1/2 watt)	33-370339	.20	Knob Volume, Tone Controls	27-4332	.10	
㊴	Condenser (.015 mfd. Tubular)	30-4226	.20	Knob Wave-Switch	27-4332	.10	
㊵	Resistor (1 megohm 1/2 watt)	33-510339	.20	Chassis Mtg. Screw	40-5935		
㊶	Field Coil Assembly	36-3039	2.75	Baffle Assembly B cabinet	40-5933		
㊷	Output Transformer	32-7019	.85	Baffle Assembly F Cabinet	L-2183	.40	
㊸	Cone and Voice Coil Assembly	36-3157	.80	A.C. Cord	L-2181	.25	
㊹	Condenser (.03 mfd. Tubular)	30-4380	.20	Speaker Cable	6440	.05	
㊺	Condenser (.008 mfd. Tubular)	30-4112	.20	Clamp Electrolytic Condenser	27-7194	.01	
㊻	Electrolytic Condenser (8 mfd.)	30-2024	1.10	Insulator Electrolytic Condenser	38-3888	.01	
㊼	Bias Resistor (245 ohm)	33-3277	.20	Grid Cap	29-6032	.04	
㊽	Electrolytic Condenser 12 mfd.	30-2117	1.20	Spacer Compensating Condenser	W-1653 FA-3	Per C .30	
㊾	Power Transformer (50-60 cycle 105-120 volt)	32-7583	4.25	Screw	36-1009	5.75	
㊿	*Power Transformer (25 cycle 115 volt)	32-7584		Speaker S7	W-124	Per C .35	
1	Condenser Bakelite Twin (.015-.015 mfd.)	3793 DG	.40	Nut Speaker Mtg.	W-1604	Per C .50	
2	Tone Control & AC Switch	42-1180	.75	Screw Speaker Mtg.	28-3895 FA-3		
3	Pilot Lamp	34-2039	.15	Bottom Shield Plate (F Cabinet)			

\*Power Transformer used in Model 37-61A

Prices Subject to Change Without Notice